

Preparation:

- Print the A4 page containing the four badge templates.
- Photocopy the required amount of badges onto card (*if available*).
- If unable to photocopy onto card, cut out the required amount of card rectangles (*9 cm x 6 cm*) - this will be the 'backing' for the badges.

Instructions:

1. Colour/decorate badges as desired.
2. Cut along the dotted lines. (*If already on card, simply cut around the solid line and go to step 5*).
3. Glue card backing to the badges, ensuring the edge of the card is in line with the solid lines of the badge outline.
4. Fold each tab (*dashed line*) over and stick to the back of the card using glue or sticky tape.
5. Attach safety pin. Either use a hole punch to create a hole at the top of the badge to thread the safety pin through, or attach to the back of the badge by gluing a strip of cardboard (*craft glue could be used*) vertically and threading the safety pin through as shown below.

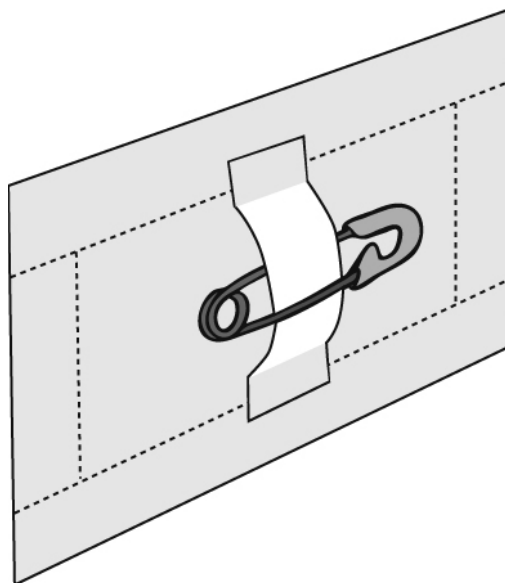

HARMONY DAY

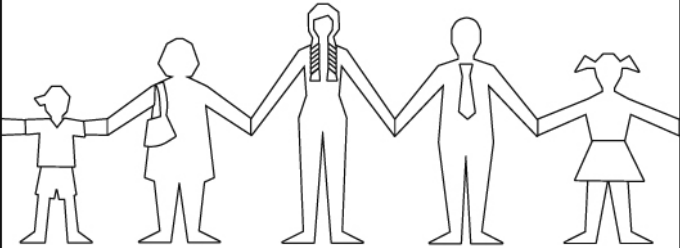

HARMONY DAY

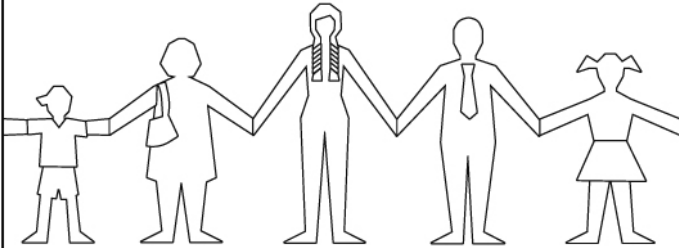

HARMONY DAY

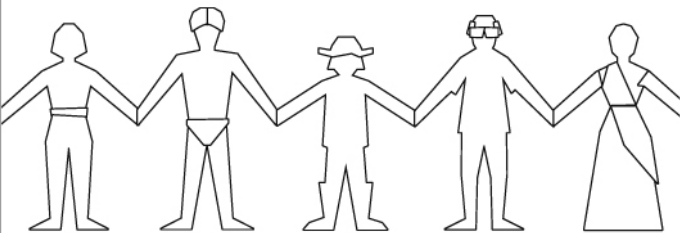

HARMONY DAY

